

7" Reel x 12mm Tape for SMD Packing

7 英寸卷盘 12 毫米载带 SMD 贴片包装

1. Packing Method 包装方法

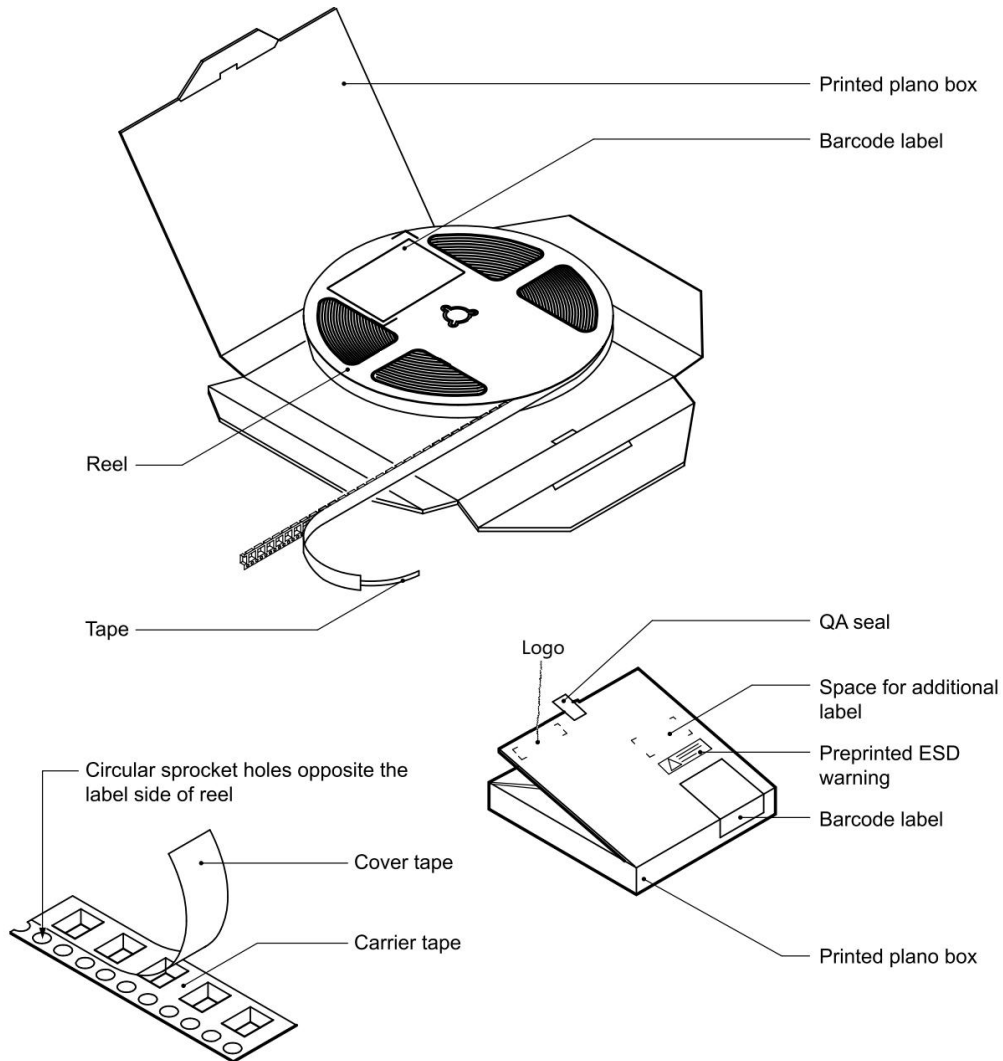

Figure1. Reel pack for SMD



Packing Information

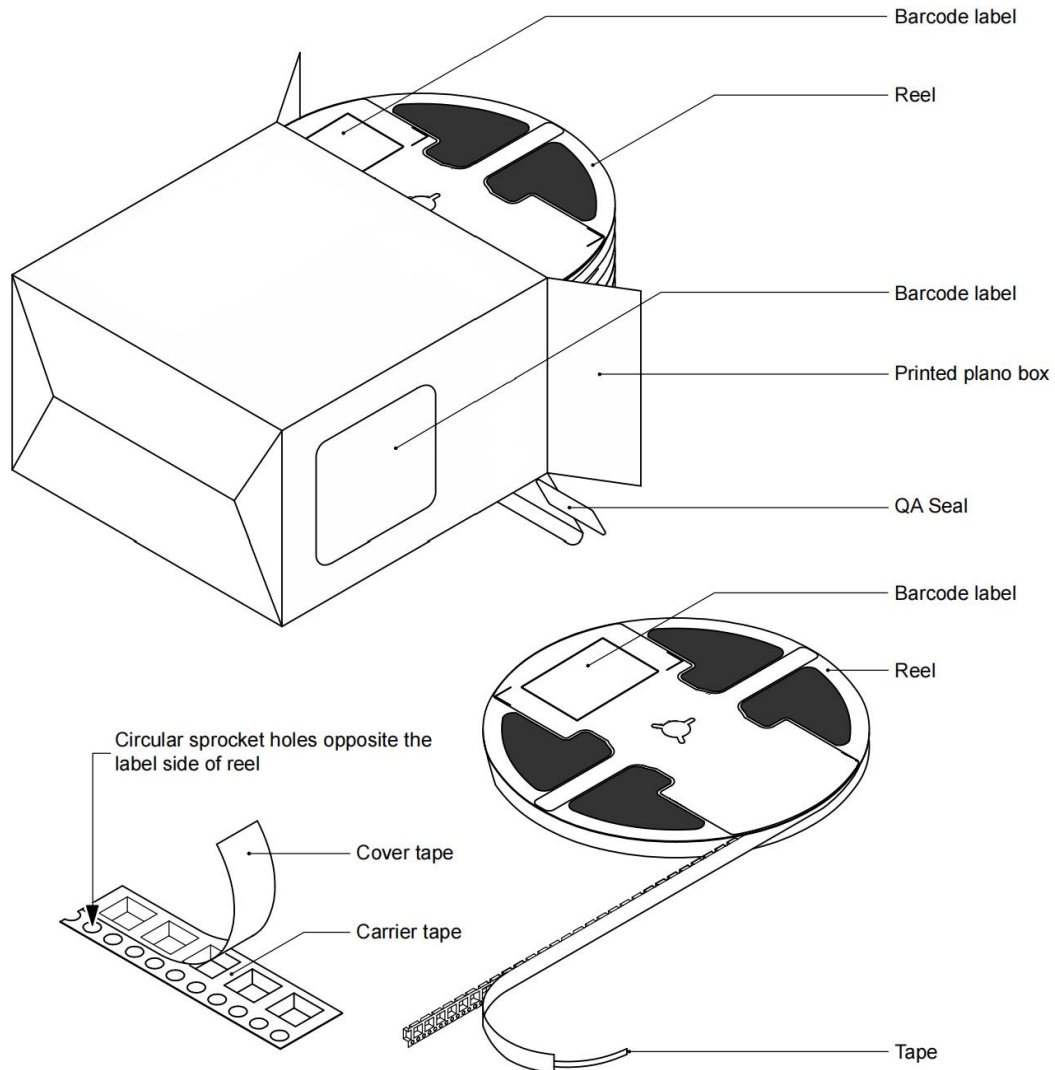

Figure2. Multi reel pack for SMD

Note: Reel appearance subject to actual product.

说明: 卷盘外观以实物为准。

Table1. Dimensions and quantities

Package	Reel Size	Tape width (mm)	Reels per box	Quantity (pcs)	Outer box dimensions l × w × h (mm)
SOT-89	7"	12	1	1000	185 x 185 x 23
SMA	7"	12	1	1800	185 x 185 x 23
SOT-89	7"	12	10	10000	185 x 185 x 145
SMA	7"	12	10	18000	185 x 185 x 145

2. Tape Orientation 载带方向

Package	Tape width(mm)	Tape Orientation
SOT-89	12	
SMA	12	

Figure3. Product orientation in carrier tape

3. Carrier tape dimensions 载带尺寸

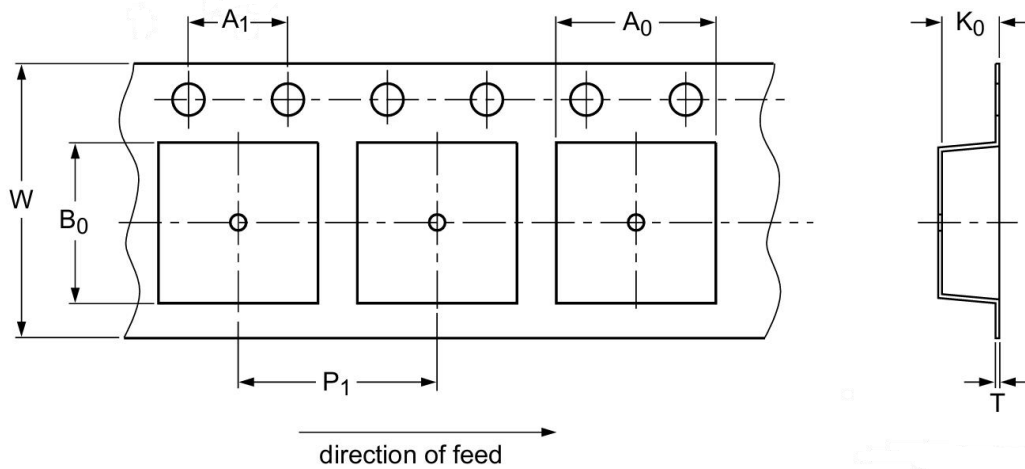

Figure4. Plastic/Embossed carrier tape

Table2. Typical carrier tape dimensions

Package	A0(mm)	A1(mm)	B0(mm)	K0(mm)	T(mm)	P1(mm)	W(mm)
SOT-89	5	4	4.5	1.2	0.3	8	12
SMA	3.5	4	5.8	2	0.25	4	12

Note: A0, B0, K0, determined by component size

说明: A0, B0, K0 由元器件尺寸决定。

4. Reel Dimensions 卷盘尺寸

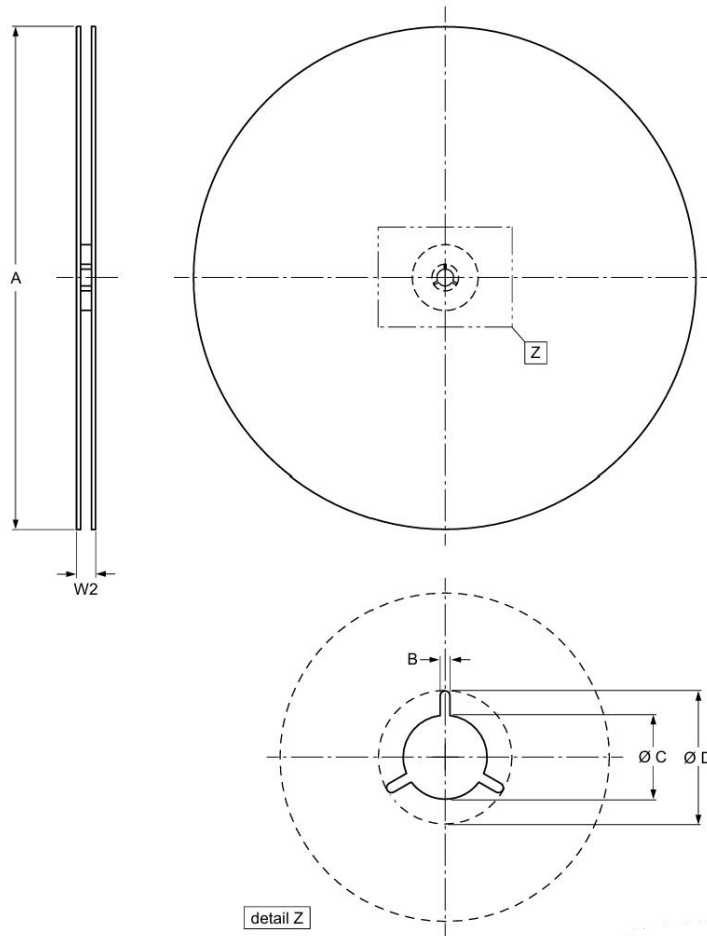

Figure5. Schematic view of reel

Table3. Typical Carrier tape dimensions

A(mm)	W2(mm)	B(mm)	C(mm)	D(mm)
178±2	14	3	13.5	22.5

5. Barcode label 条形码标签

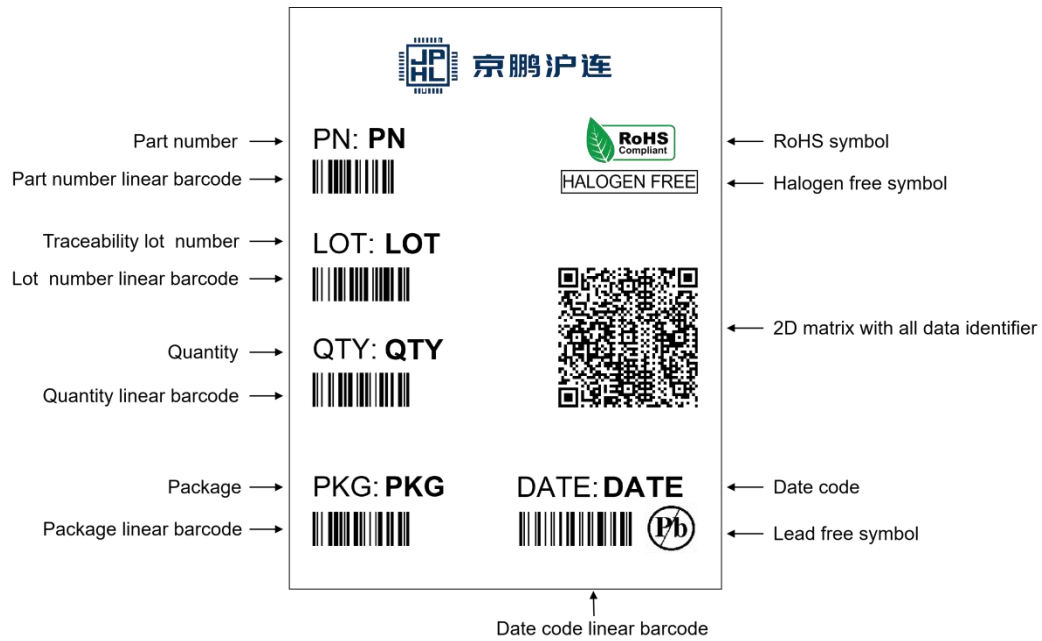

Figure6. Example of typical box information barcode label



Figure7. Example of typical reel information barcode label

Table 4. Barcode label dimensions

Box barcode label l × w (mm)	Reel barcode label l × w (mm)
102 x 76	43.5 x 100



Important Notice 重要通知

Jingpeng Hulian('JPHL') company make no warranty of any kind,express or implied,with regards to any information contained in this document.Including,but not limited to, the implied warranties of the accuracy, completeness, merchantability, or non-infringement of third party intellectual property rights.

京鹏沪连公司(以下简称“JPHL”)对本文件包含的所有信息不提供任何明示或默认的担保,包括但不限于关于信息的准确性、完整性、适销性,以及不侵犯第三方知识产权的默认保证。

The Information contained herein is for informational purpose only and is provided only to illustrate the operation of JPHL products described herein and application examples. JPHL does not assume any liability arising out of the application or use of this document or any product described herein.

本文件内容仅作信息参考,仅用于说明文中所述 JPHL 产品的操作方法及应用示例。JPHL 不承担因应用或使用本文件或本文件中描述的任何产品而产生的任何责任。

JPHL reserves the right to make changes to information published in this document, at any time and without notice. This document supersedes and replaces all information supplied prior to the publication hereof.

JPHL 保留随时修改本文件已发布信息权利,且不另行通知,本文件将取代并替换其发布前提供的所有相关信息。

All referenced brands, product names, service names and trademarks are the property of their respective owners.

本文提及的所有品牌、产品名称、服务名称和商标,均归属其各自所有者。



Contents 目录

1. Packing Method 包装方法	1
2. Tape Orientation 载带方向	3
3. Carrier tape dimensions 载带尺寸	3
4. Reel Dimensions 卷盘尺寸	4
5. Barcode label 条形码标签	5
Important Notice 重要通知	6

© JPHL. 2025. All rights reserved

For more information, please visit: www.jphl-semi.com

For business cooperation, please send an email to: sales@jphl-semi.com

Date of release: 26 Dec 2025

©京鹏沪连. 2025. 版权所有

想了解更多信息, 请访问 www.jphl-semi.com

商务合作请发送电子邮件至 sales@jphl-semi.com

发布日期: 2025-12-26
